

50 Liter Liquid Nitrogen Storage Dewar

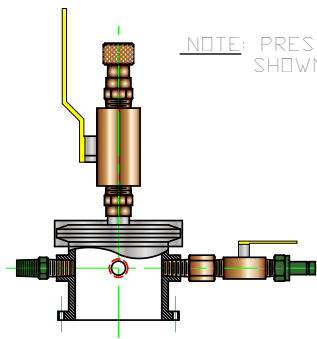

50 Liter Low Pressure Liquid Nitrogen Storage Dewar Features:

- High efficiency aluminum/fiberglass construction
- 50 Liter nominal liquid nitrogen capacity
(25 liter also available)
- Low pressure use only (10 psi max)
- Internal charcoal cryopump vacuum maintenance system
- Optional header to fit liquid cryogen transfer line with:
 - Central transfer line inlet port with valve
 - Safety pressure relief
 - Pressure gage
 - Gas vent valve
(line sold separately)



NOTE: PRESSURE GAUGE NOT SHOWN IN THIS VIEW

OPTIONAL HEADER

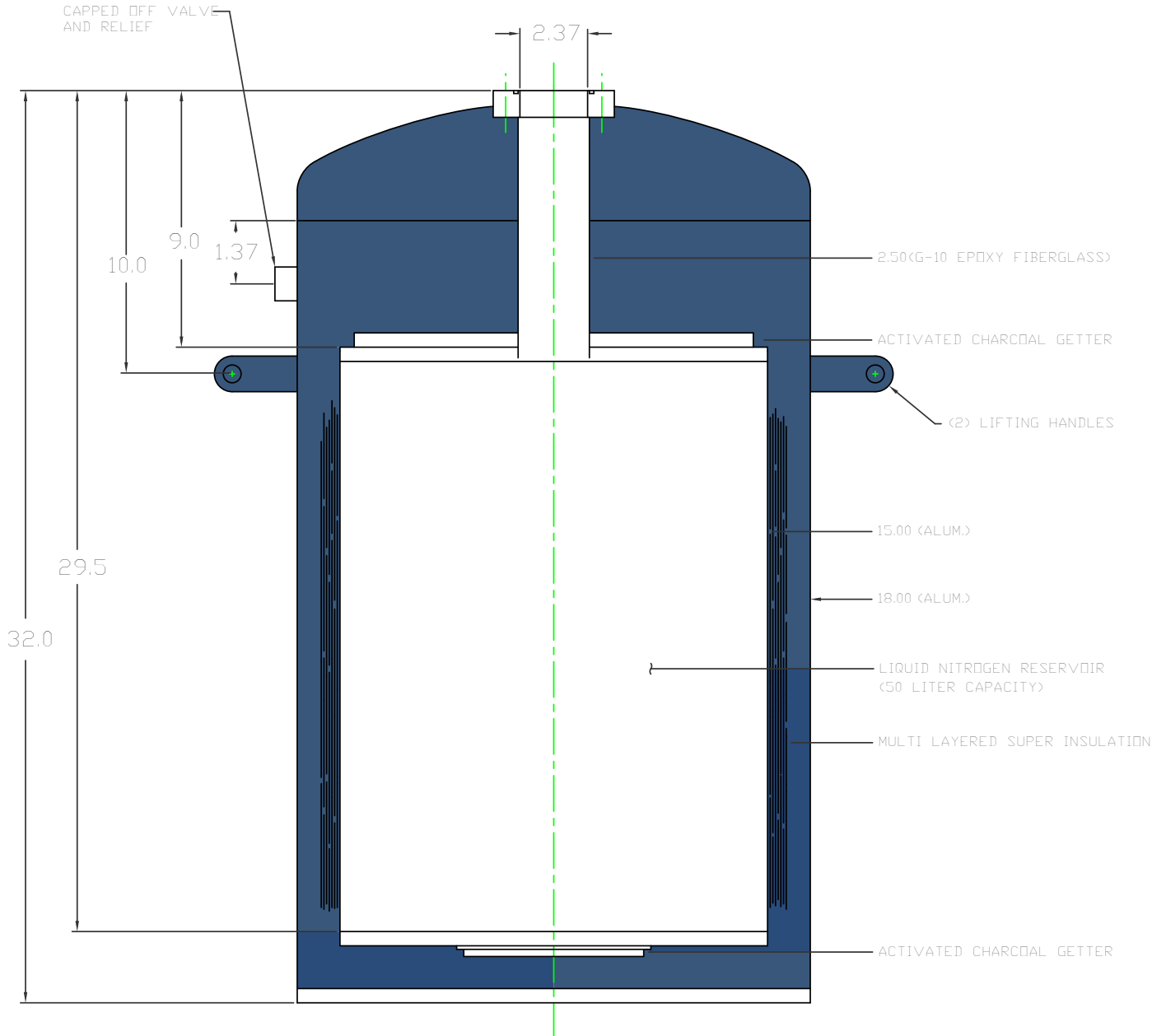

CRYO
Industries of America, Inc.
11 Industrial Way, Atkinson N.H. 03811
TITLE: MULTI SHIELDED
LIQUID NITROGEN DEWAR